

# VKC-1327A/WDDG2

Home | Security | Dome Cameras | Fixed

VKC-1327A/WDDG2

1/3" Dome, Fixed, Day&Night, clear, 3.8-9.5mm,

540TVL, 12VDC/24VAC

**Art-Nr. 92167**



## Main Features

For wall and drop-ceiling mounting

Vandal and tamper-resistant

Clear Lexan bubble with inner liner

1/3" day&night CCD board camera with varifocal lens

Built-in lens F1.2/3.8-9.5mm with DC iris control

Resolution of 540 horizontal lines

Removable IR cut filter

Automatic shutter control (AES)

Backlight compensation (BLC)

Manual 3-axis camera adjustment

For easy indoor and outdoor installation

## Specifications

Video standard	CCIR/PAL
System	day&night, CCIR/PAL
Sensor size	1/3"
Imager	CCD, Sony Super HAD Interline Transfer
Active picture elements	440,000, 752(H) x 582(V)
Synchronization	Internal/Line-lock (automatic detection depend on power source)
Signal-to-noise ratio	48dB
Sensitivity (at 50% video signal)	0,5 Lux, (colour), 0.24Lux (B&W) at F1.2 (measured)
Horizontal resolution	540 TVL
Automatic gain control (AGC)	Normal/Turbo (+6dB)
Rotation range	manual: 360°
Automatic electronic shutter (ESC)	1/50 - 1/100,000sec.
Low speed shutter	no

# VKC-1327A/WDDG2

(Continuation Specifications)

<b>Digital Noise Reduction (DNR)</b>	no
<b>White balance (ATW)</b>	2000 ~8000K, Automatic
<b>Backlight compensation</b>	BLC
<b>Gamma correction</b>	approx. 0.45
<b>Backlight compensation</b>	ON/OFF switchable
<b>Wide Dynamic Range (WDR)</b>	no
<b>IR cut filter</b>	switchable
<b>Video outputs</b>	composite (CVBS), 1Vp-p, CVBS, 75ohms
<b>Lens type</b>	varifocal
<b>Lens</b>	F1.2/F2.0~360 / 3.8~9.5mm with galvanometer controlled iris
<b>Focal length</b>	3,8 mm - 9,5 mm
<b>Horizontal angle of view</b>	74,2° - 30°
<b>Digital zoom</b>	no
<b>Iris control</b>	DC
<b>MOD (Minimum object distance)</b>	0,15 m
<b>Focus range</b>	0.15m ~∞
<b>Filter screw size</b>	not available
<b>Alarm outputs</b>	-
<b>Illumination</b>	no
<b>Activity detection</b>	no
<b>Motion detector</b>	no
<b>Internal adjustments</b>	8 Dip switches: Internal/Line-lock synchronization, ELC/ALC (Shutter/Auto-Iris), BLC ON/OFF, AGC Normal/Turbo, Flickerless ON/OFF, Sharpness Normal/Sharp, Day/Night mode Enabled/Disabled, IR mode ON/OFF (Iteration reduction between day and night position). 2 Potentiometers: Level for DC controlled iris, V. phase adjustment (220° min. adjustable)
<b>Cable connection</b>	Video (BNC), Power (2 pin screw terminal)
<b>Cable entry</b>	3/4" and 1/2" thread for conduit glands, lock stopper included
<b>Serial interfaces</b>	no
<b>Temperature range (operation)</b>	-10°C ~+50°C
<b>Heater</b>	optional
<b>Thermostat switching points</b>	+2.4°C ON / +22°C OFF (heater kit 12V, #71664, optional)
<b>Temperature range with built-in heater</b>	-30°C ~+50°C
<b>Protection rating</b>	IP65
<b>Protection rating</b>	at installation according to the manual
<b>Supply voltage</b>	12VDC, 24VAC
<b>Supply voltage</b>	12VDC (10.5~30VDC) 24VAC (12~29VAC)
<b>Power consumption</b>	approx. 3.0watts
<b>Vandalism resistant</b>	yes
<b>Bubble</b>	PC plastic bubble with inner liner, vandal resistant

# VKC-1327A/WDDG2

(Continuation Specifications)

<b>Colour (bubble)</b>	clear,
<b>Mounting</b>	ceiling mount, wall mount
<b>Housing</b>	outdoor
<b>Housing</b>	Die-cast aluminium with clear polycarbonate bubble
<b>Housing material</b>	aluminium
<b>Colour (housing)</b>	Pantone Cool Gray 1C
<b>Dimensions (HxWxD)</b>	see drawing,
<b>Weight</b>	approx. 750g
<b>Parts supplied</b>	Mounting kit, 1/2" gland, Blind covers, Torx wrench key
<b>Certificates</b>	CE

## Optional accessories

<b>77773</b>	<b>VT-PS12DCDT1</b>	PSU 12VDC/1.0A, Regulated, Desktop Version, 1.8m Cables each w. open ends
<b>70495</b>	<b>VT-PS12DC-7</b>	Plugable PSU w. Cont. & UK Mains plug-in 100-240VAC/12VDC-1.25A, Regulated
<b>88149</b>	<b>3/4" - M25X1.5</b>	Thread Adapter 3/4" - Conduit Connection M25x1.5mm for Dome Surface Mount Housing
<b>71664</b>	<b>WDDG2/H12</b>	Low Voltage Heater Kit 12V/8W for WDDG-2 housing
<b>70543</b>	<b>VT-PS12DC-10</b>	Plugable AC/DC Adapter 100-240V/12VDC- 2.5A, stab., Cont. & UK Mains plug-ins

# VKC-1327A/WDDG2

Home | Security | Dome Cameras | Fixed

## Technical drawing

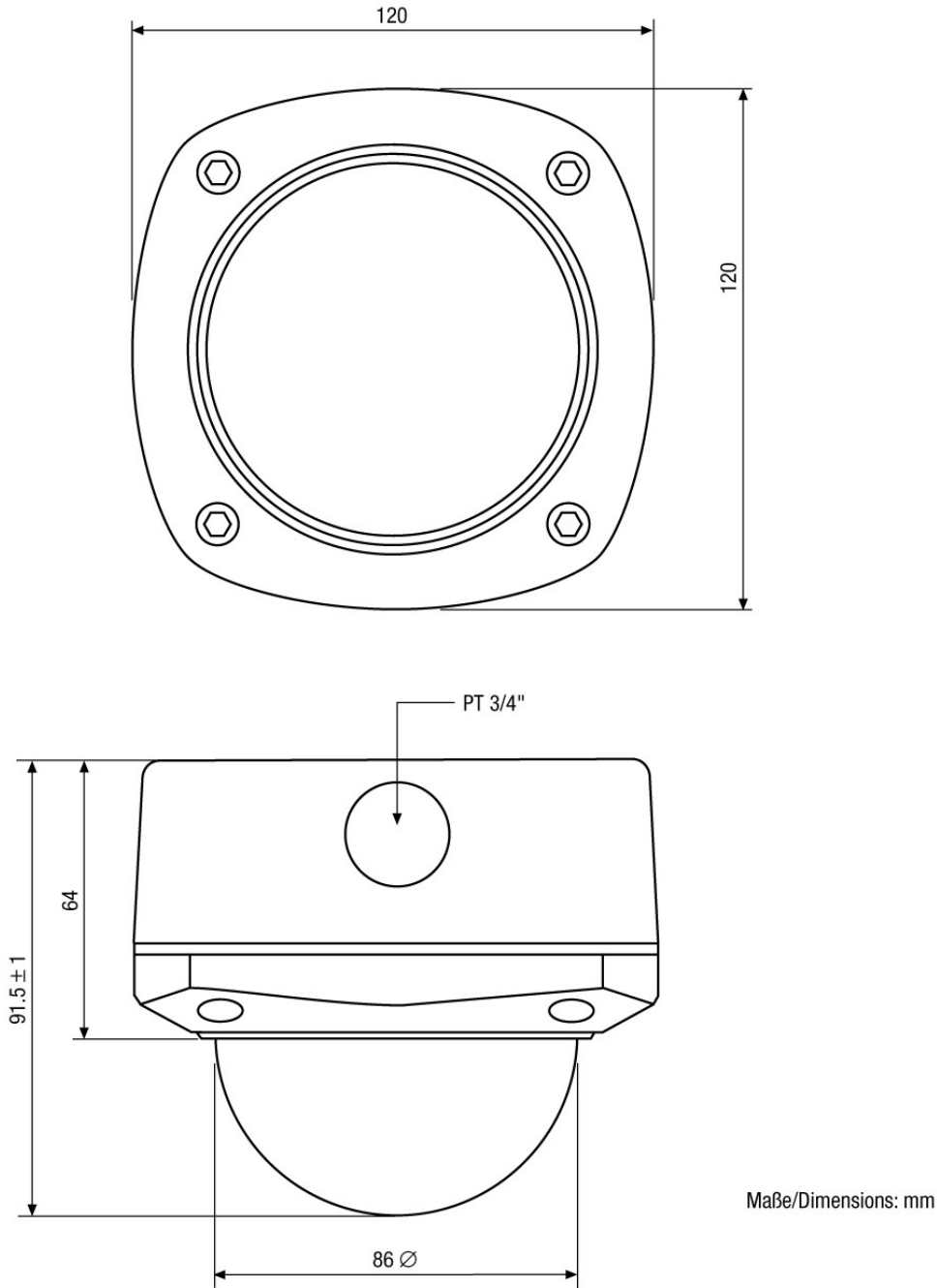

SLD Security & Communications  
The Old Forge, Ockham Lane, Ockham, Surrey GU236PH England  
Phone +44.1483225633 · Fax +44.1483225634  
sales@sld.co.uk · www.sld.co.uk

