

EGLC-3

Home | Security | Processing | Accessories

EGLC-3
Ground-Loop Corrector, BNC/BNC,

Art-Nr. 72612



Main Features

Provides Ground Isolation
Compatible with Coax Control Systems

Isolated BNC Connectors
No Power Requirement

Specifications

Colour	RAL9003
Weight	110g
Bandwidth	10Hz ~7MHz
Differential phase (at 3.58 MHz)	Negligible
Differential gain (at 3,58 MHz)	Negligible
In-/Output	BNC connectors
Impedance	75Ohm unbalanced
Ground isolation	115db at 50Hz
Dielectrical strength	500Vrms at 50Hz
Housing	plastic
Dimensions (HxWxD)	30x55x85mm

EGLC-3

Home | Security | Processing | Accessories

Technical drawing

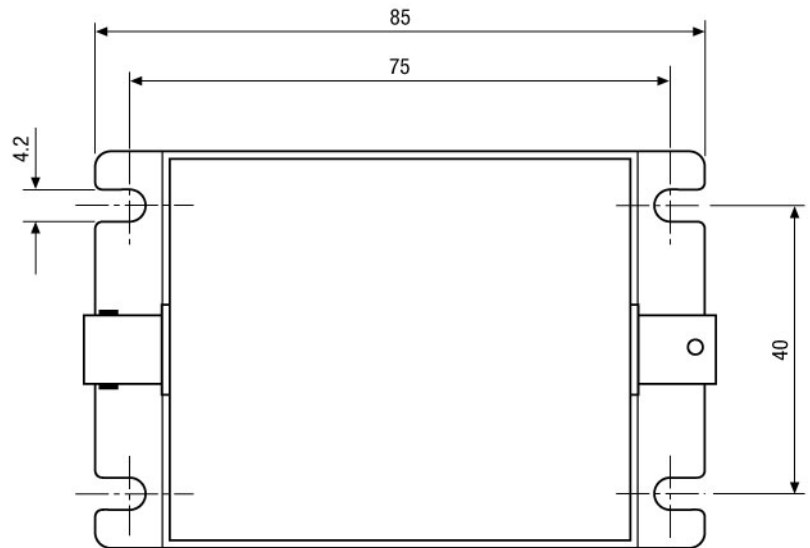
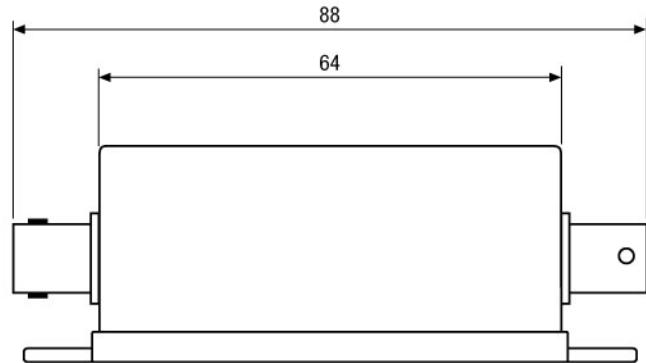
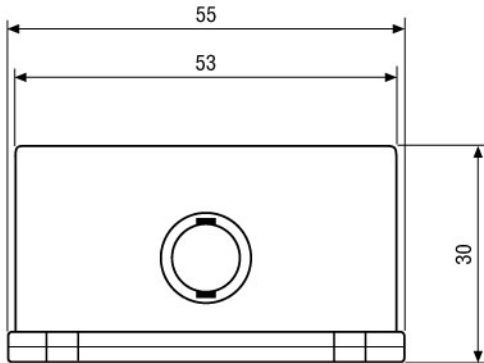

Maße/Dimensions: mm

SLD Security & Communications
The Old Forge, Ockham Lane, Ockham, Surrey GU236PH England
Phone +44.1483225633 · Fax +44.1483225634
sales@sld.co.uk · www.sld.co.uk

